



DEPARTMENT OF THE ARMY

THE INSTITUTE OF HERALDRY
9325 GUNSTON ROAD, ROOM S113
FORT BELVOIR, VIRGINIA 22060-5579

AAMH-IHS

30 November 2018

MEMORANDUM FOR Commander, US Army Futures Command, ATTN:
COL Rosendo Guieb, 210 W 7th St., Suite 15.300, Austin, TX 78701

SUBJECT: Authorized Insignia for US Army Futures Command (AFC)

1. The following heraldic items are authorized for AFC, effective 1 July 2018.

a. A distinctive unit insignia (Encl 1). The description and symbolism of the design are as follows:

DESCRIPTION

On a shield shaped gold metal and epoxied device 1 3/16" (3.02cm) in height blazoned as follows: Argent, pily of eight issuant from fess Sable, overall a horizontal anvil Or. Attached below the shield, a black scroll bearing the inscription "**FORGE THE FUTURE**" in gold.

SYMBOLISM

The golden anvil alludes to GEN Eisenhower's coat of arms, representing fortitude, determination, and perseverance. Furthermore, the piles emanating from the anvil emphasize the motto "**FORGE THE FUTURE**" by dynamically radiating outward with energy, fueled by ingenuity, creativity, and purpose. The colors black, white, and gold are emblematic of the US Army.

b. A shoulder sleeve insignia (Encl 2). The description and symbolism of the design are as follows:

DESCRIPTION

On a shield shaped embroidered item edged with a 1/8" (0.32cm) black border, blazoned as follows: Per fess enarched Argent and Gris, between x, a pile inverted throughout Sable; overall in base a horizontal anvil Or. Overall dimensions are 3 1/4" (8.26cm) in height by 2 1/2" (6.35cm) in width.

AAMH-IHS

SUBJECT: Authorized Insignia for US Army Futures Command (AFC)

SYMBOLISM

The golden anvil alludes to GEN Eisenhower's coat of arms, representing fortitude, determination, and perseverance. Furthermore, the anvil emphasizes the motto "**FORGE THE FUTURE**". The arched division of the shield conveys a horizon, complimented by the piles, to indicate forces uniting worldwide towards a common goal. The colors black, white, and gold are emblematic of the US Army.

- c. A beret flash (Encl 3).
 - d. Distinguishing colors IAW AR 840-10 (Encl 4).
2. This authorization is in accordance with AR 670-1, AR 840-10 and Headquarters, Department of the Army General Order No. 2018-10. A copy of this letter will become part of your permanent organizational history files.
3. Your point of contact for this action is Mr. Garrison at keith.a.garrison6.civ@mail.mil or 571-515-0324.

Encls

CHARLES V. MUGNO
Director

CF:
The U.S. Army Center of Military History



US ARMY FUTURES COMMAND

****This Drawing is 6x-Actual Size****

ACTUAL SIZE-----1 3/16" ± 1/64" High (3.02 cm ± 0.04 cm)

METAL COLOR & PLATING-----Gold
 FINISH-----Mirror-like polish

DESIGN
 CHARGES-----Flush, except anvil to be modeled & superimposed upon base

LETTERING-----Finished metal
 PIERCING-----None, area between scroll and shield to be recessed and textured

EPOXY-----Stoning
 CHIP No's-----Black #26, White #28

**TYPE V D-6997(X)
 BASE & DEVICE (ASSEMBLED)**

**FOR COLOR PLACEMENT ONLY
 NOT FOR COLOR MATCH**

APPROVED

*THE INSTITUTE OF HERALDRY,
 DEPARTMENT OF THE ARMY*

MUGNO.CHARLE MUGNO.CHARLES.V.10207
 23374
 S.V.1020723374 2018.10.23 14:34:57 -04'00'

*CHARLES V. MUGNO
 DIRECTOR*

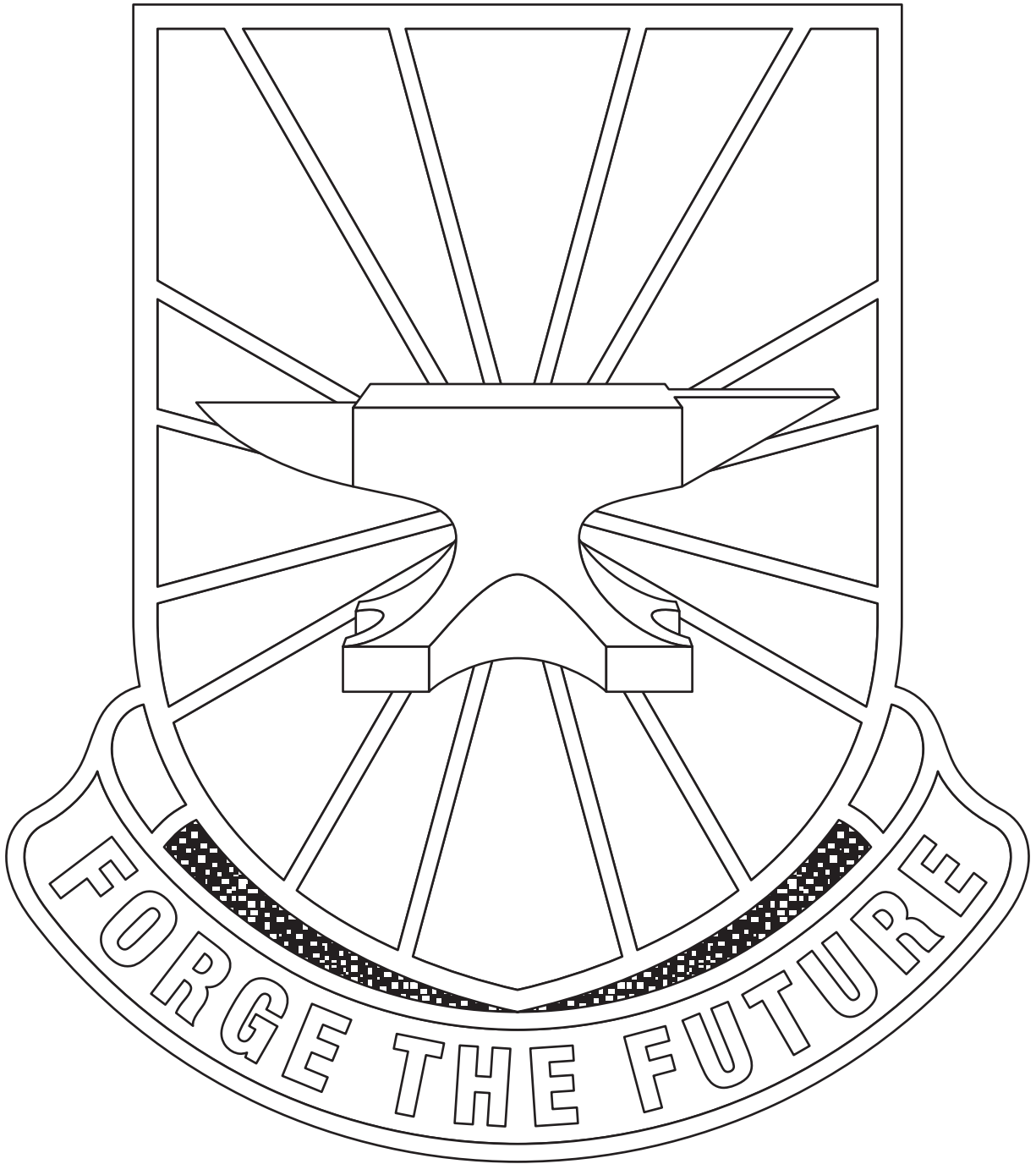

US ARMY FUTURES COMMAND

**TYPE V D-6997(X)
BASE & DEVICE (ASSEMBLED)**

****This Drawing is 6x-Actual Size****

ACTUAL SIZE-----1 3/16" ± 1/64" High (3.02 cm ± 0.04 cm)

METAL COLOR & PLATING-----Gold
FINISH-----Mirror-like polish

DESIGN
CHARGES-----Flush, except anvil to be modeled & superimposed upon base

LETTERING-----Finished metal
PIERCING-----None, area between scroll and shield to be recessed and textured

EPOXY-----Stoning
CHIP No's-----Black #26, White #28

APPROVED

**THE INSTITUTE OF HERALDRY,
DEPARTMENT OF THE ARMY**

**MUGNO.CHARLE
S.V.1020723374**

MUGNO.CHARLES.V.1020
723374
2018.10.23 14:35:18
-04'00'

**CHARLES V. MUGNO
DIRECTOR**

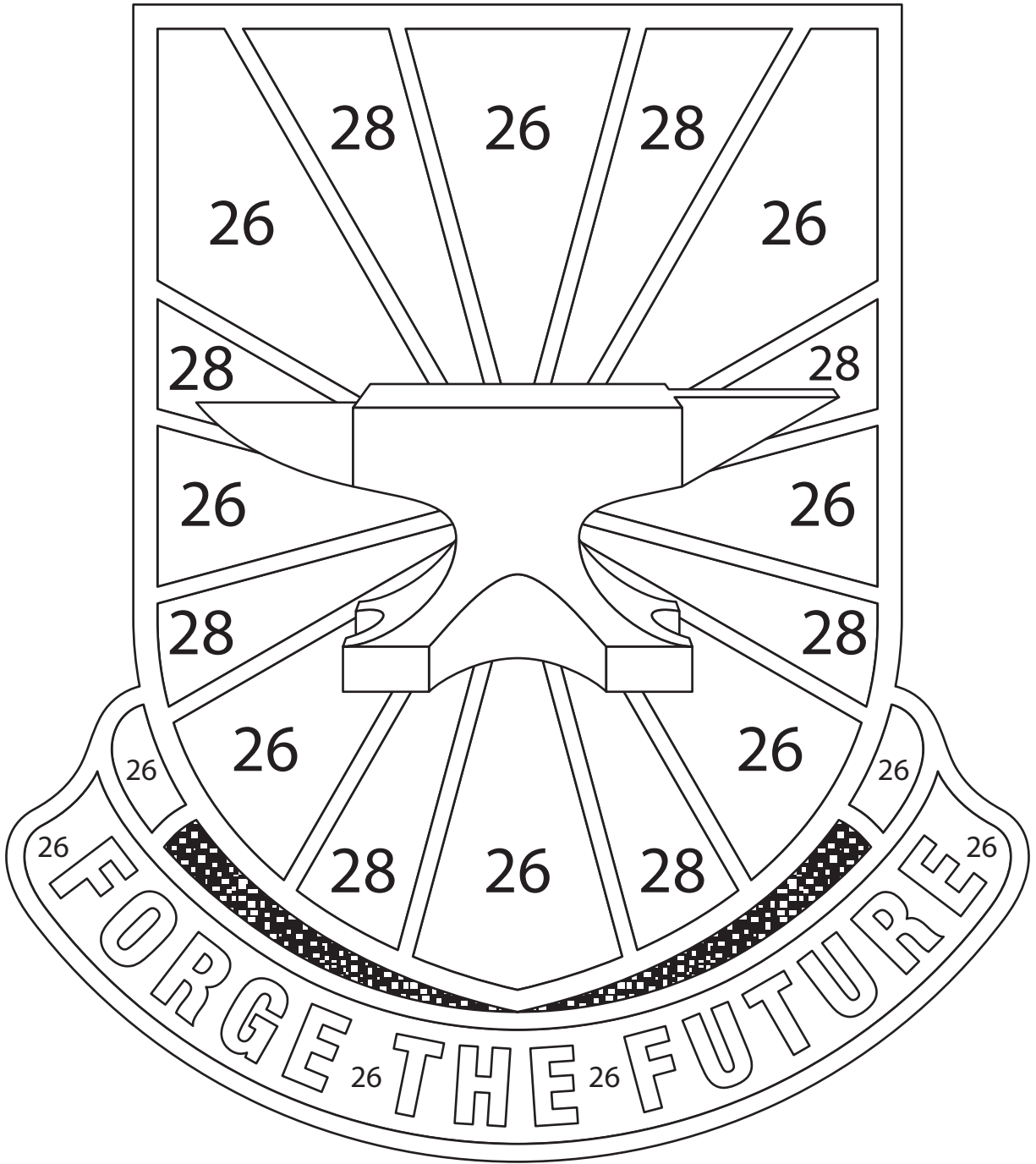

US ARMY FUTURES COMMAND

**TYPE V D-6997(X)
BASE & DEVICE (ASSEMBLED)**

****This Drawing is 6x-Actual Size****

ACTUAL SIZE-----1 3/16" ± 1/64" High (3.02 cm ± 0.04 cm)

METAL COLOR & PLATING-----Gold

FINISH-----Mirror-like polish

DESIGN

CHARGES-----Flush, except anvil to be modeled & superimposed upon base

LETTERING-----Finished metal

PIERCING-----None, area between scroll and shield to be recessed and textured

EPOXY-----Stoning

CHIP No's-----Black #26, White #28

APPROVED

THE INSTITUTE OF HERALDRY,
DEPARTMENT OF THE ARMY

MUGNO.CHARLE MUGNO.CHARLES.V.10207
23374
S.V.1020723374 2018.10.23 14:35:29 -04'00'

CHARLES V. MUGNO
DIRECTOR

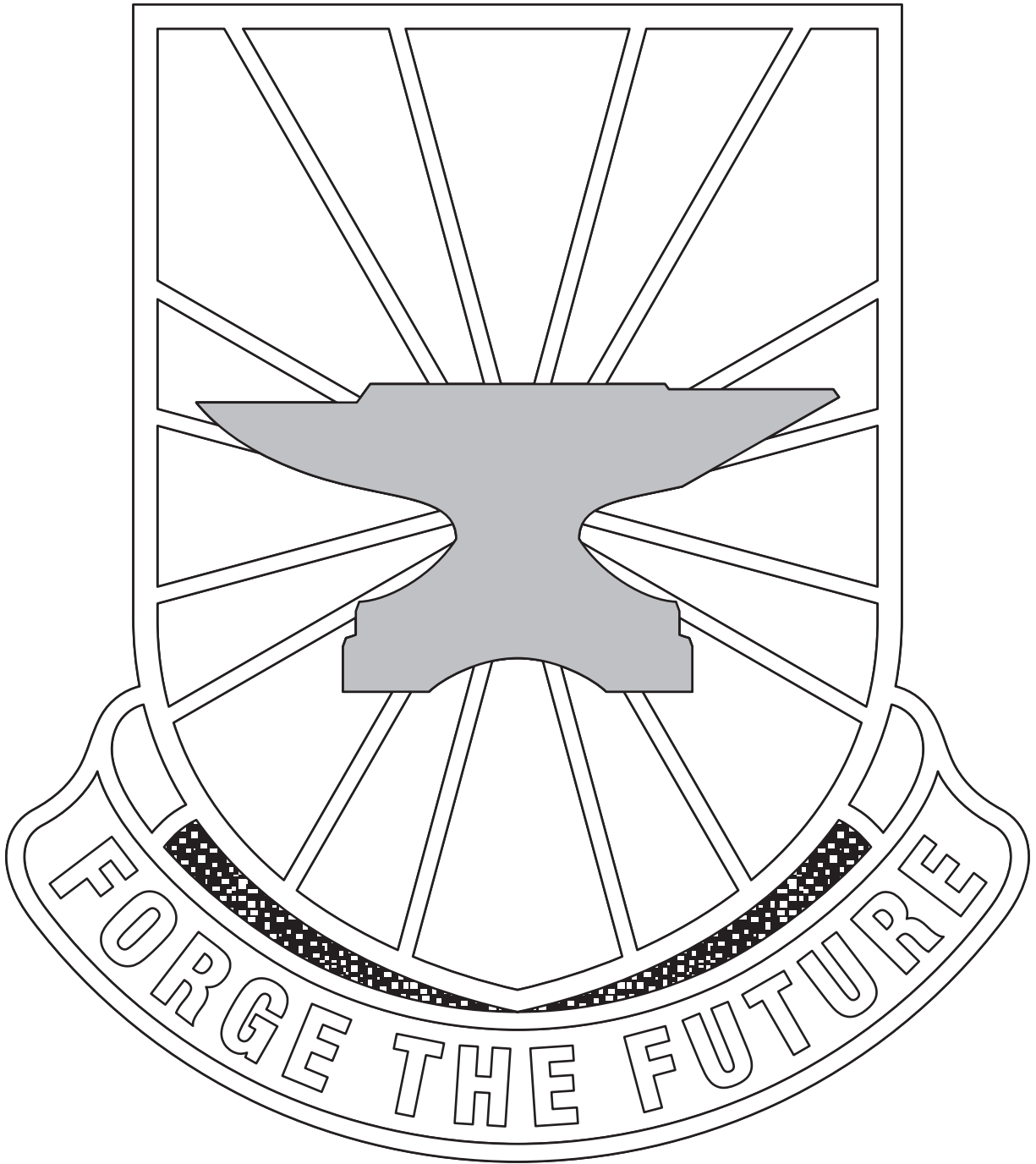

US ARMY FUTURES COMMAND

**TYPE V D-6997(X)
BASE (UNASSEMBLED)**

****This Drawing is 6x-Actual Size****

ACTUAL SIZE-----1 3/16" ± 1/64" High (3.02 cm ± 0.04 cm)

METAL COLOR & PLATING-----Gold
FINISH-----Mirror-like polish

DESIGN
CHARGES-----Flush, except anvil to be modeled & superimposed upon base

LETTERING-----Finished metal
PIERCING-----None, area between scroll and shield to be recessed and textured

EPOXY-----Stoning
CHIP No's-----Black #26, White #28

APPROVED
**THE INSTITUTE OF HERALDRY,
DEPARTMENT OF THE ARMY**

MUGNO.CHARLE MUGNO.CHARLES.V.10207
23374
S.V.1020723374 2018.10.23 14:35:42 -04'00'

CHARLES V. MUGNO
DIRECTOR

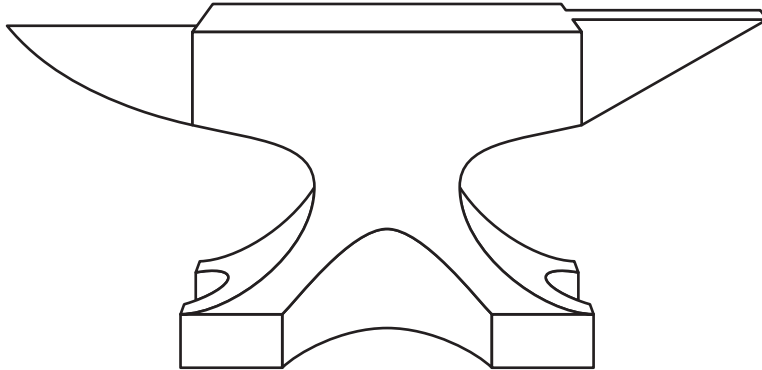

US ARMY FUTURES COMMAND

TYPE V D-6997X DEVICE (UNASSEMBLED)

****This Drawing is 6x-Actual Size****

ACTUAL SIZE-----21/32" ± 1/64" Wide (1.67 cm ± 0.04 cm)

METAL COLOR & PLATING-----Gold

FINISH-----Mirror-like polish

DESIGN

CHARGES-----Anvil to be modeled

APPROVED

***THE INSTITUTE OF HERALDRY,
DEPARTMENT OF THE ARMY***

MUGNO.CHARLE MUGNO.CHARLES.V.102
0723374
S.V.1020723374 2018.10.23 14:35:55
-04'00'

**CHARLES V. MUGNO
DIRECTOR**

AWW

FOR SUBDUED INSIGNIA

OCP:

BLACK AREAS TO BE BLACK 67138.
 WHITE & YELLOW AREAS TO BE BAGBY
 GREEN 67204. GRAY AREAS TO BE OLIVE
 DRAB 67133.

REVISIONS

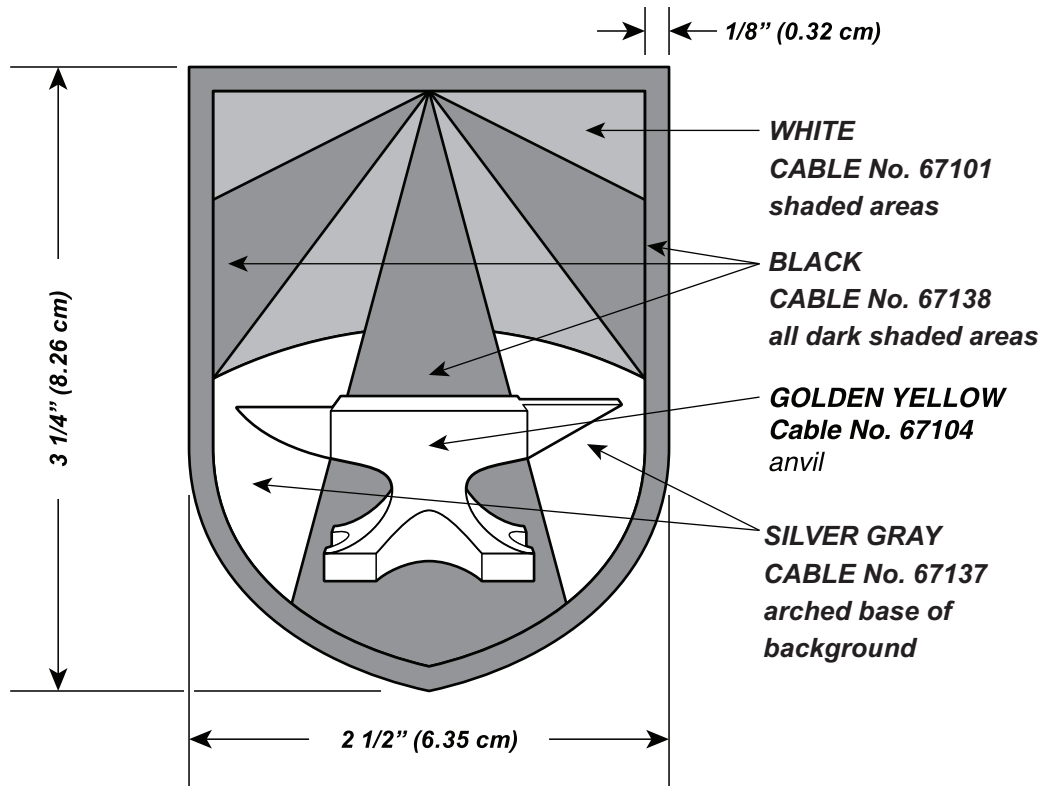

DESIGNED FOR OVEREDGE STITCHING

STITCH COUNT

6613 STICHES (minimum)
90/2 DENIER
12/4 SPAN

EXAMINED	<i>TLC</i>	
CHECKED	<i>CA</i>	<i>SAO</i>
PREPARED	AWW	
APPROVED	MUGNO.CHARLE MUGNO.CHARLES.V.10207 23374 S.V.1020723374 2018.10.23 14:34:22 -04'00' <hr/> CHARLES V. MUGNO DIRECTOR	
MATERIALS: TO BE MANUFACTURED IN ACCORDANCE WITH MIL-DTL-14652		

THE INSTITUTE OF HERALDRY, DEPARTMENT OF THE ARMY		
9325 GUNSTON RD, RM S-113 FORT BELVOIR, VA 22060-5579		
SHOULDER SLEEVE INSIGNIA		
U. S. ARMY		
FUTURES COMMAND		
SIZE	CONTROL IDENT. NO	A - 1 - 1127
A	22571	
SCALE	FULL	DATE
		23 OCTOBER 2018

SHOULDER SLEEVE INSIGNIA
US ARMY FUTURES COMMAND



COLOR



OCP

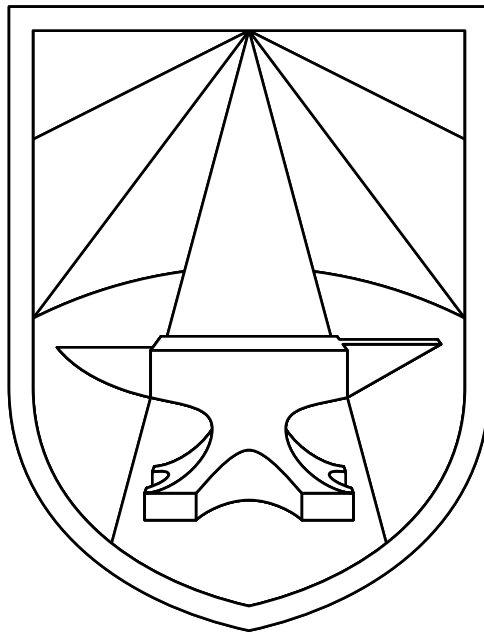

LINE

THE INSTITUTE OF HERALDRY
DEPARTMENT OF THE ARMY
9325 GUNSTON ROAD, ROOM S113
FORT BELVOIR, VIRGINIA 22060-5579

APPROVED



CHARLES V. MUGNO
DIRECTOR

REVISIONS

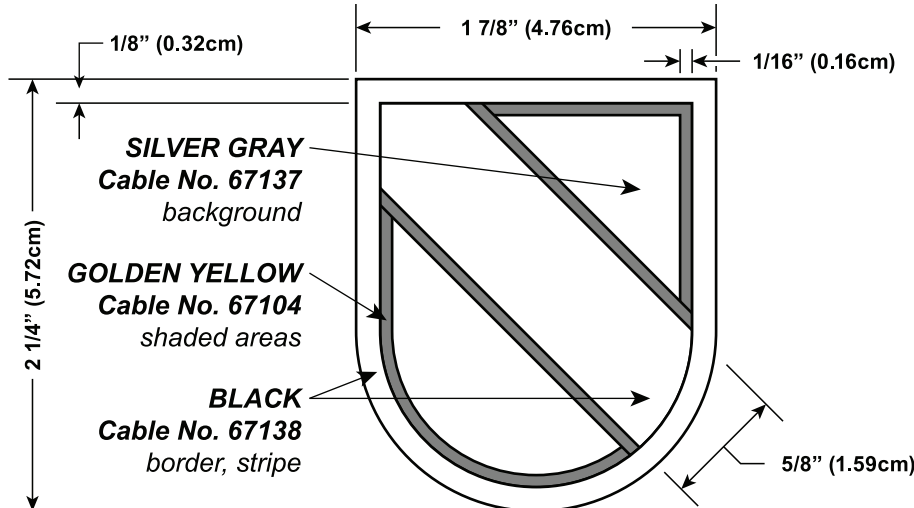

DESIGNED FOR OVEREDGE STITCHING

EXAMINED	<i>TLC</i>	
CHECKED	<i>CA</i>	<i>SAO</i>
PREPARED	AWW	
APPROVED	MUGNO.CHARLE MUGNO.CHARLES.V.10207 23374 S.V.1020723374 2018.10.23 14:33:51 -04'00' <hr/> CHARLES V. MUGNO DIRECTOR	

THE INSTITUTE OF HERALDRY, DEPARTMENT OF THE ARMY
 9325 GUNSTON RD, RM S-113 FORT BELVOIR, VA 22060-5579

BERET FLASH FOR
U. S. ARMY
FUTURE'S COMMAND

SIZE	CONTROL IDENT. NO	A-4-322
A	22571	

MATERIALS: TO BE MANUFACTURED IN ACCORDANCE WITH MIL-DTL-14652 SCALE FULL DATE **23 OCTOBER 2018**

REVISIONS
SUPERSEDES TIOH DWG No. 5-1-0717 DTD 17 AUG 2011

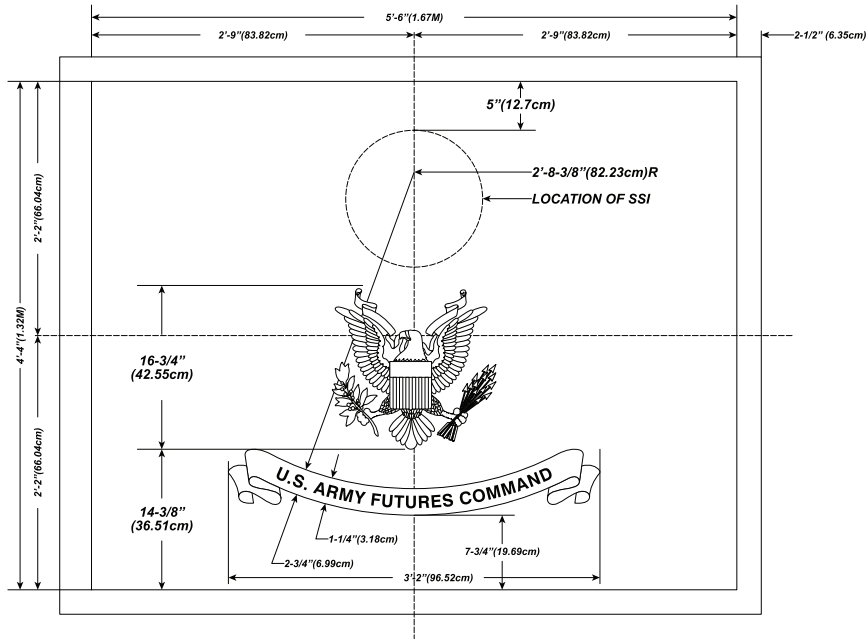

No. OF LINE	DESIGNATION	SHOULDER SLEEVE INSIGNIA		
		HEIGHT	PIPING	DWG No.
1.	FORCES COMMAND**	13" (33.02 cm)	REQUIRED	A-1-192
2.	US ARMY TRAINING AND DOCTRINE COMMAND**	13" (33.02 cm)	REQUIRED	A-1-558
3.	US ARMY MATERIEL COMMAND	15" (38.1cm)	NOT REQUIRED	A-1-305
4.	US ARMY FUTURES COMMAND	15" (38.1cm)	REQUIRED	A-1-1127

**ARMY GREEN BORDER OF SSI NOT USED ON FLAG

MATERIAL:

FLAG BASE.....RAYON BANNER CLOTH
FRINGE.....RAYON, 2-1/2" WIDTH
SSI.....RAYON APPLIQUE
EAGLE.....SCHIFFLI EMBROIDERY
SHIELD.....RAYON EMBROIDERY
MOTTO SCROLL.....RAYON APPLIQUE
MOTTO.....MACHINE EMBROIDERY
DESIGNATION SCROLL.....RAYON APPLIQUE
BORDERS OF SCROLL.....MACHINE EMBROIDERY
DESIGNATION.....MACHINE EMBROIDERY

COLORS AND CABLE NUMBERS OF COLORS CLOTH YARN

FLAG BASE.....NATIONAL FLAG BLUE.....80077
FRINGE.....YELLOW.....67108
SSI.....PROPER
EAGLE.....PROPER
MOTTO SCROLL.....YELLOW.....65002
MOTTO.....BLACK.....67138
BORDERS.....YELLOW.....67108
SHIELD-CHIEF.....FLAG BLUE.....67124
STRIPES-ALTERNATING.....WHITE.....67101
AND.....SCARLET.....67111
DESIGNATION SCROLL.....WHITE
BORDERS.....YELLOW.....67108
DESIGNATION.....FLAG BLUE.....67124

NOTES:

- TO BE MANUFACTURED IN ACCORDANCE WITH LATEST REVISION OF SPECIFICATION MIL-DTL-2962.
- EAGLE TO BE SCHIFFLI EMBROIDERY UTILIZING THE SAME COMPONENTS USED FOR INFANTRY ORGANIZATIONAL COLORS; SHIELD TO BE EMBROIDERY; MOTTO SCROLL TO BE APPLIQUE WITH MOTTO EMBROIDERED.
- SHOULDER SLEEVE INSIGNIA TO BE APPLIQUE.
- DESIGNATION SCROLL TO BE APPLIQUE WITH BORDERS AND LETTERS TO BE EMBROIDERY. BORDERS TO BE 3/16" WIDE.
- SHOULDER SLEEVE INSIGNIA TO BE PIPED WITH 1/4" WHITE EMBROIDERY IF REQUIRED.
- EAGLE, SHIELD, MOTTO SCROLL, SSI AND DESIGNATION SHALL APPEAR ON BOTH SIDES AS IF PRINTED THROUGH. SSI AND DESIGNATION SCROLL WILL APPEAR AS ILLUSTRATED ON BOTH SIDES AND ALL LETTERING WILL READ FROM LEFT TO RIGHT ON BOTH SIDES.
- FOR EAGLE SEE TIOH CARTOON No. 5-6-2-1 THROUGH 5-6-2-5.
- FOR MOTTO SCROLL AND MOTTO SEE TIOH DWG No. 5-6-1A.
- FOR HEADING SEE TIOH DWG No. 5-1-45E.
- ALL DIMENSIONS ARE EXCLUSIVE OF HEMS.
- DESIGNATION SHALL APPEAR EXACTLY AS THEY APPEAR IN THE CHART ABOVE RIGHT.

EXAMINED	<i>PLC</i>	THE INSTITUTE OF HERALDRY, DEPARTMENT OF THE ARMY
CHECKED	<i>CA</i>	9325 GUNSTON RD, RM S-113 FORT BELVOIR, VA 22060-5579
PREPARED	<i>AW</i>	DISTINGUISHING FLAGS FOR
APPROVED		ARMY COMMANDS
MUGNO.CHARLES	MUGNO.CHARLES.V.10207233	SIZE CODE IDENT. NO
.V.1020723374	2018.10.23 14:33:13 -04'00'	D 22571
CHARLES V. MUGNO	DIRECTOR	SCALE FULL DATE 22 OCTOBER 2018