



REPLY TO
ATTENTION OF

DEPARTMENT OF THE ARMY
THE INSTITUTE OF HERALDRY
9325 GUNSTON ROAD, ROOM S112
FORT BELVOIR, VIRGINIA 22060-5579

AAHS-IHS (840-10a)

JAN 22 2015

MEMORANDUM FOR Commander, 294th Quartermaster Company, ATTN: SFC Michael Kanzler, 5102 F Emma Browning Avenue, Del Valle, TX 78617

SUBJECT: Beret Flash and Background Trimming for the 294th Quartermaster Company

1. The request for a beret flash and background trimming for the 294th Quartermaster Company is approved. Forwarded for your organizational records is the authorization letter (encl 1).
2. Also enclosed for use in procurement of the items are:
 - a. Manufacturing drawings for the flash and trimming (TIOH Dwg. No. A-4-298 and A-6-326) (encls 2 and 3).
 - b. Color prints and black and white line drawings of the flash and trimming (encls 4 and 5).
 - c. A list of certified manufacturers and procedures for local procurement of insignia (encls 6 and 7).
3. POC this Institute is Mrs. Henning by telephone at DSN 656-4972, Commercial (703) 806-4972 or by email at Bonnie.Henning@us.army.mil.

7 Encls
as

CHARLES V. MUGNO
Director



REPLY TO
ATTENTION OF

DEPARTMENT OF THE ARMY
THE INSTITUTE OF HERALDRY
9325 GUNSTON ROAD, ROOM S112
FORT BELVOIR, VIRGINIA 22060-5579

JAN 22 2015

AAHS-IHS (840-10a)

MEMORANDUM FOR Commander, 294th Quartermaster Company, ATTN: SFC Michael Kanzler, 5102 F Emma Browning Avenue, Del Valle, TX 78617

SUBJECT: Beret Flash and Background Trimming for the 294th Quartermaster Company

1. In accordance with the provisions of AR-670-1, a beret flash and background trimming are authorized for wear by members of the 294th Quartermaster Company.
2. The descriptions of the designs are as follows:

BERET FLASH

A shield-shaped embroidered item with a semi-circular base 2 1/4 inches (5.72 cm) in height and 1 7/8 inches (4.76 cm) in width overall, left half cobalt blue, the right side divided upper quarter white and lower quarter scarlet; all within a 1/8 inch (.32 cm) buff border.

BACKGROUND TRIMMING

An oval-shaped embroidered item 1 3/8 inches (3.49 cm) in height and 2 1/4 inches (5.72 cm) in width overall, left half cobalt blue, the right side divided upper quarter white and lower quarter scarlet; all within a 1/8 inch (.32 cm) buff border.

CABLE NUMBERS OF COLORS

Buff	#67135
Cobalt Blue	#67122
White	#67101
Scarlet	#67111

AAHS-IHS (840-10a)

SUBJECT: Beret Flash and Background Trimming for the 294th Quartermaster Company

3. This authorization does not grant exclusive use of the above colors and pattern design for the 294th Quartermaster Company.

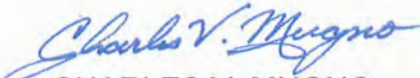

CHARLES V. MUGNO
Director

CF: CMH

REVISIONS

LTR	DESCRIPTION	DATE	APPROVED
-----	-------------	------	----------

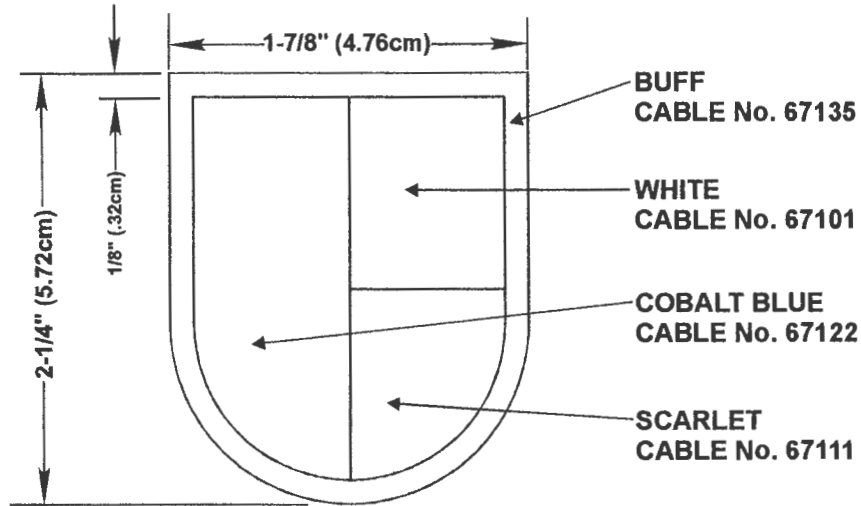

DESIGNED FOR OVEREDGE STITCHING

UNLESS OTHERWISE SPECIFIED DIMENSIONS ARE IN INCHES
TOLERANCES ON FRACTIONS DECIMALS ANGLES

MATERIALS:
TO BE MANUFACTURED IN ACCORDANCE WITH MIL-DTL-14652

EXAMINED	<i>SaO</i>
CHECKED	<i>CS</i>
PREPARED	GS
APPROVED	<i>Charles V. Mugno</i> CHARLES V. MUGNO DIRECTOR

THE INSTITUTE OF HERALDRY, DEPARTMENT OF THE ARMY
9325 GUNSTON RD, RM S-113 FORT BELVOIR, VA 22060-5579

BERET FLASH FOR

294TH QUARTERMASTER COMPANY

SIZE	CONTROL IDENT. NO	A-4-298
A	22571	
SCALE	FULL	DATE
		13 JANUARY 2015

REVISIONS

LTR	DESCRIPTION	DATE	APPROVED
-----	-------------	------	----------

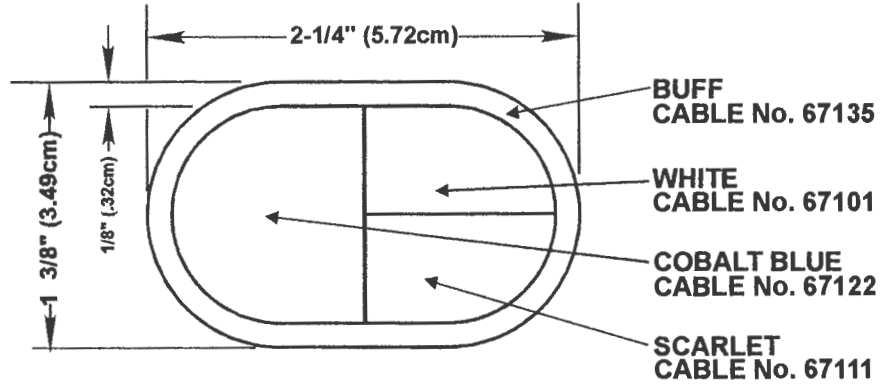

DESIGNED FOR OVEREDGE STITCHING

UNLESS OTHERWISE SPECIFIED DIMENSIONS ARE IN INCHES
TOLERANCES ON FRACTIONS DECIMALS ANGLES

MATERIALS:
TO BE MANUFACTURED IN ACCORDANCE WITH MIL-DTL-14652

EXAMINED	<i>SAD</i>	
CHECKED	<i>CS</i>	
PREPARED	GS	
APPROVED	<i>Charles V. Mugno</i>	
	CHARLES V. MUGNO DIRECTOR	

THE INSTITUTE OF HERALDRY, DEPARTMENT OF THE ARMY
9325 GUNSTON RD, RM S-113 FORT BELVOIR, VA 22060-5579

BACKGROUND TRIMMING FOR
294TH QUARTERMASTER COMPANY

SIZE	CONTROL IDENT. NO	A-6-326
A	22571	
SCALE	FULL	DATE
		5 JANUARY 2015

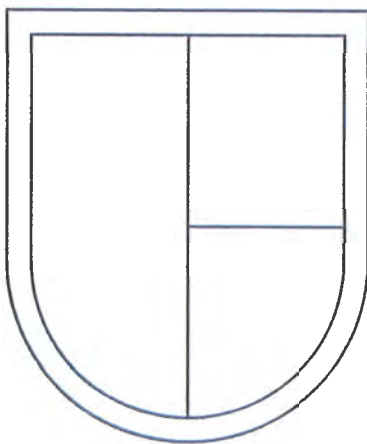
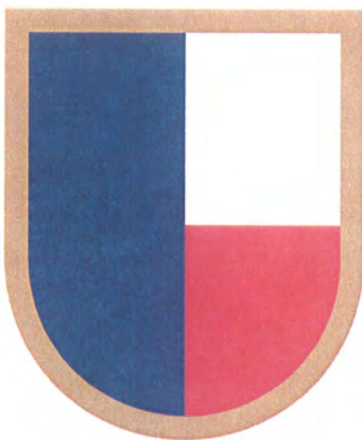

**BERET FLASH
294TH QUARTERMASTER COMPANY**

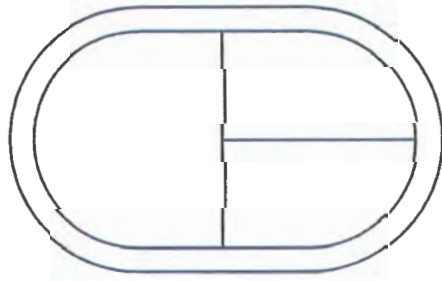
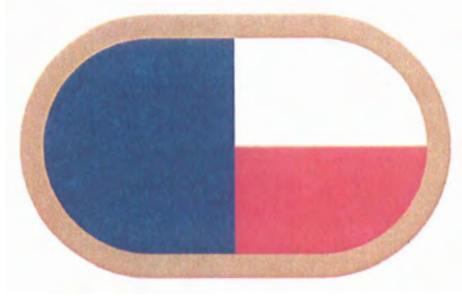

**BACKGROUND TRIMMING
294TH QUARTERMASTER COMPANY**